

Foundations & Wind loading

Further information on foundations and wind loading for Altron products can be found on the following pages. This contains useful information which may help when assessing and planning projects using Altron CCTV products.

Foundation sizes for elevated sites and Area D

The table below shows foundation sizes for area D installations and, for exposed, elevated locations, higher than 100-150m above sea level. For areas A,B and C the left hand column shows the foundation size shown in the product foundation page - read across the table for the relevant foundation size to be used for the relevant location.

e.g. in the foundations table on p21 an ACC2/BPLA for country location in area B has a foundations size of 1.2 x 1.2 x 0.6 but the location is at 300m ASL. Look for the foundation size in the left hand column of the table below and read across the row to the 'Elevated foundation' column for the correct foundation size, for the elevated location.

- o For locations above 350m above sea level (ASL) and area D locations above 250m ASL, please contact Altron who will advise on product suitability and foundation sizes.
- o Products marked with an asterisk in their foundation page are note suitable for installations in Area D or in area C above 200m. Please select an alternative product.

Foundation size Shown in product Foundations table Area A&B 0-100m Area C 0-150m	Area D foundation size to be used (0-250m ASL) instead of area C foundation	Area A&B foundation sizes for elevated sites 100-200m ASL	Area A&B foundation sizes for elevated sites 200-350m ASL	Area C foundation sizes for elevated sites 150-350m ASL
0.8 x 0.8 x 0.4	0.9 x 0.9 x 0.5	0.9 x 0.9 x 0.5	1.0 x 1.0 x 0.5	0.9 x 0.9 x 0.5
0.9 x 0.9 x 0.5	1.0 x 1.0 x 0.5	1.0 x 1.0 x 0.5	1.1 x 1.1 x 0.55	1.0 x 1.0 x 0.5
1.0 x 1.0 x 0.5	1.1 x 1.1 x 0.55	1.1 x 1.1 x 0.55	1.2 x 1.2 x 0.6	1.1 x 1.1 x 0.55
1.1 x 1.1 x 0.55	1.2 x 1.2 x 0.6	1.2 x 1.2 x 0.6	1.3 x 1.3 x 0.65	1.2 x 1.2 x 0.6
1.2 x 1.2 x 0.6	1.3 x 1.3 x 0.65	1.3 x 1.3 x 0.65	1.4 x 1.4 x 0.7	1.3 x 1.3 x 0.65
1.3 x 1.3 x 0.65	1.4 x 1.4 x 0.7	1.4 x 1.4 x 0.7	1.5 x 1.5 x 0.75	1.4 x 1.4 x 0.7
1.4 x 1.4 x 0.7	1.5 x 1.5 x 0.75	1.5 x 1.5 x 0.75	1.6 x 1.6 x 0.8	1.5 x 1.5 x 0.75
1.4 x 1.4 x 0.75	1.5 x 1.5 x 0.75	1.5 x 1.5 x 0.75	1.6 x 1.6 x 0.8	1.5 x 1.5 x 0.75
1.5 x 1.5 x 0.75	1.6 x 1.6 x 0.8	1.6 x 1.6 x 0.8	1.7 x 1.7 x 0.9	1.6 x 1.6 x 0.8
1.6 x 1.6 x 0.8	1.7 x 1.7 x 0.9	1.7 x 1.7 x 0.9	1.8 x 1.8 x 0.9	1.7 x 1.7 x 0.9
1.7 x 1.7 x 0.9	1.8 x 1.8 x 0.9	1.8 x 1.8 x 0.9	1.9 x 1.9 x 1.0	1.8 x 1.8 x 0.9
1.8 x 1.8 x 0.9	1.9 x 1.9 x 1.0	1.9 x 1.9 x 1.0	2.0 x 2.0 x 1.0	1.9 x 1.9 x 1.0
1.9 x 1.9 x 1.0	2.0 x 2.0 x 1.0	2.0 x 2.0 x 1.0	2.1 x 2.1 x 1.1	2.0 x 2.0 x 1.0
2.0 x 2.0 x 1.0	2.1 x 2.1 x 1.1	2.1 x 2.1 x 1.1	2.2 x 2.2 x 1.1	2.1 x 2.1 x 1.1
2.1 x 2.1 x 1.1	2.2 x 2.2 x 1.1	2.2 x 2.2 x 1.1	2.3 x 2.3 x 1.2	2.2 x 2.2 x 1.1
2.2 x 2.2 x 1.1	2.3 x 2.3 x 1.2	2.3 x 2.3 x 1.2	2.4 x 2.4 x 1.2	2.3 x 2.3 x 1.2
2.3 x 2.3 x 1.2	2.4 x 2.4 x 1.2	2.4 x 2.4 x 1.2	2.5 x 2.5 x 1.2	2.4 x 2.4 x 1.2

ASL = Above Sea Level

Notes on foundations

- o Grade C28/35 concrete to be used.
- o Allow a minimum of 72 hours for concrete to cure before placing pole/column/tower.
- o A minimum ground bearing capacity of 75 kN/m² is assumed.
- o Foundations comply with BS EN 1997-1:2004, BS 8004, ILE TR7 and PLG07.
- o Foundation sizes are based on foundations being founded on natural ground. For made up ground, further assessment on ground suitability may be required.
- o Foundation sizes shown are suitable for maximum equipment load and wind surface area as shown in product technical tables. For greater loads, foundations sizes will need to be increased, please contact us and we will advise on product suitability for greater loads and foundation requirements.
- o Foundation sizes shown are not suitable for installations that include PV/ solar panels or small wind turbines. For this type of installation please contact our Sales office.

Foundation sizes in table are W x W x D

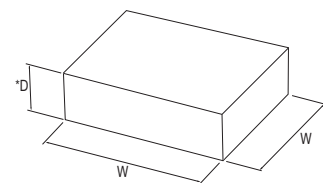

*D= 1000 on PM and buried flange/embedded base models

Factors that effect foundation sizes & installations wind surface area

The main factor that determines foundation size (other than the location of the installation), is the wind surface area of the equipment being mounted on the pole/ tower/ column. It is the wind surface area that produces the wind force (kgf) that transfers itself to the foundation, for which the foundation needs to be of sufficient size to overcome the 'over turning moment' produced by this lever force. The greater the surface area of equipment at the top of the structure, the larger the foundation size required, so it is very important that the 'Max equip surface area' shown in our technical tables is not exceeded. An extreme example of this is a solar panel which can be very light - only a few kilograms, but can have a large surface area and therefore require a much larger foundation size than the ones we state.

UK wind speed map

The UK map shows Basic Mean Hourly windspeeds with the contour lines defining areas A,B,C and D. Windspeeds are shown at sea level and for every 100m increase in altitude, the Basic Mean Hourly windspeed increases by 10%, then giving the Site Mean Windspeed.

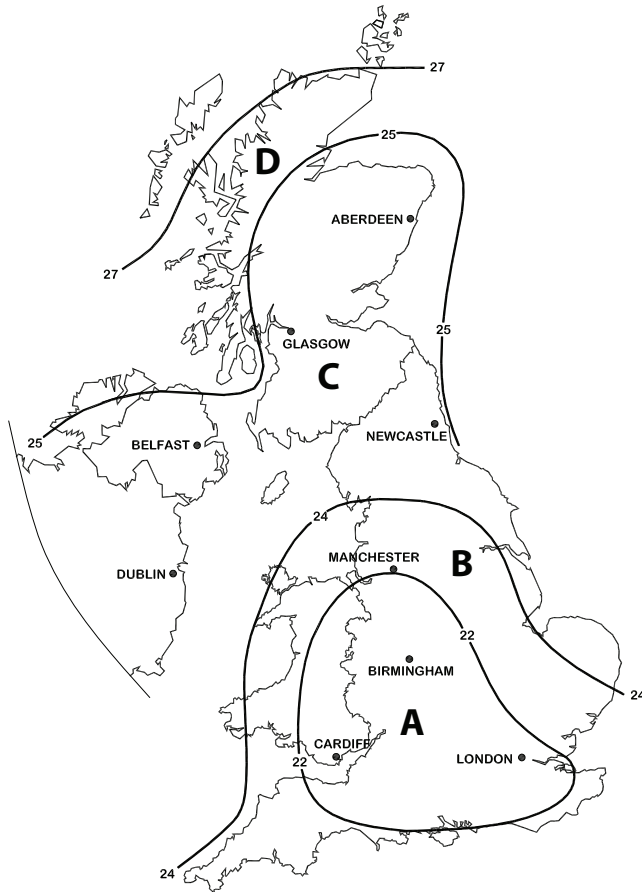

Explanation of Town Location and County Location used in the foundation sizes tables on each product Foundation & Bolting Details page.

Definition of 'Town location' - Town locations are locations within built up areas, with at least 15% of the surface built on, and/or on which the average height of buildings exceed 15m - for locations on outskirts that do not comply with this, 'Country location' for foundation sizes should be used.

Definition of 'Country location' - All areas, both coastal, up to 100m ASL and inland up to 200m ASL, that are not 'Town locations' (see table for higher altitudes).

STANDARD					AREA A & B FOUNDATIONS UPTO 200m ASL			AREA AB & C FOUNDATIONS UPTO 350m ASL		
Area	Max Basic Mean Hourly Windspeed	Height above sea level for foundation design	Site mean wind speed	Actual wind velocity	Height above sea level for foundation design	Site mean wind speed	Actual wind velocity	Height above sea level for foundation design	Site mean wind speed	Actual wind velocity
A	22 m/s	100m	24.2 m/s	41.8 m/s (93 mph)	200m	26.4 m/s	45.6 m/s (102 mph)	350m	29.7 m/s	51.4 m/s (115 mph)
B	24 m/s	100m	26.4 m/s	45.6 m/s (102 mph)	200m	28.8 m/s	50 m/s (111 mph)	350m	32.4 m/s	56 m/s (125 mph)
C	25 m/s	150m	28.8 m/s	50 m/s (111 mph)	N/A	N/A	N/A	350m	33.75 m/s	58.3 m/s (130 mph)
D	27 m/s	250m	33.75 m/s	58.3 m/s (130 mph)	N/A	N/A	N/A	N/A	N/A	N/A

International windspeed conversions

Our standard designs are based on a mean hourly wind speed of 28.8 m/s (metres per second). This table shows the conversion from this mean hourly wind speed, to other internationally recognised wind speed measurements. Conversions are taken from the International Code Council 'International Building Code'.

Mean Hourly	3 Sec Gust	10 Min Average	Fastest Mile
28.8 m/s	43.6 m/s	30.1 m/s	34.9 m/s
64.4 mph	97.5 mph	67.3 mph	78 mph
104.4 kph	158 kph	109 kph	126 kph

The actual wind velocity for a 28.8 m/s mean hourly wind speed = 50 m/s, 111 mph, 180 kph.

Specific site location foundation sizes

We can specify a more accurate foundation size for specific site locations. Foundations sizes shown in product tables are for the max allowable head load and for the highest windspeed for the Area A,B,C or D (for instance, the centre of London has a mean wind speed of 22.05 m/s rather than the 24.2 m/s we use for area A in general). Given a specific site location and maximum equipment load that will be employed, we can provide an ideal foundation size that will be the minimum required for the site. This can save on civils costs and also help when there are site restrictions for foundation size.

Foundation design service

For all products, we can provide specific foundation designs, for site conditions that do not comply with our standard designs. We are happy to provide guidance and pricing on request.

Equipment weight

The actual weight of the camera equipment does not significantly affect the foundation size, so for fixed, non-tilting products weight is not an issue. The weight of equipment is only relevant for tilt-down products, where the camera equipment weight needs to be lowered using the winch and winch cable. Weight is then very important on tilt-down products, so as not to overload the winch and cable mechanism, so for tilt-down products the stated 'max equip weight' should not be exceeded.

Off-set loads

Off-set loads on fixed poles/ towers/ columns, typically produced by using one of our PMB or POB mounting brackets, are not significant, other than the fact that an off-set load increases the deflection of the structure and the movement of the camera monitor image. Offset loads will also increase the stress on the structure, so even though most Altron poles, towers and columns have plenty of capacity for increased stress, some do not, so it is important to consult with us when anything more than a relatively small offset (600mm) is being used. Towers do not like to be twisted, so a pole is much better for an offset load than a tower, but a larger diameter pole will be needed to keep deflection to a minimum.

Offset loads on tilt-down products are not so desirable, unless in line with the direction of tilt, or if they are balanced (an equal load either side so when tilting the product, it is balanced). If the off-set load is not balanced, then this produces a side load at the hinge point, which can cause the hinge to bind, overloading the winch mechanism and is also a force that the hinge is not designed to take. We therefore recommend that a side load on a tilt-down product is only in line with the direction of tilt, or equal either side, so a balanced load.

Positioning Foundations

The following factors should be considered when assessing the location of a foundation in accordance with the type of product being used.

OFFSET OF CABLE DUCT ENTRY IN ACC/ACT BP MODELS

The off set positioning of cable duct entry for ACC/ACT products in conjunction with the direction of tilt needs to be assessed prior to installation, to ensure correct positioning of cable duct.

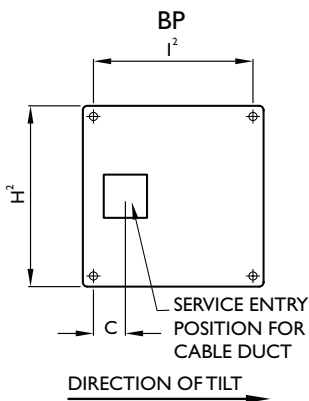

POSITIONING NEXT TO FENCE LINE

The distance from fence line or building for tilt-down products, to allow for the rear portion to tilt, needs to be assessed prior to installation. Bottom hinge alternatives allow close positioning to fence line - please contact our Sales office for details on this type of product

