

## Lowering Trolley Head Poles ←



AWI545/LTH Cabinet Based



AWI502/LTH Lamp Standard



AWI502/LTH/I68/SN Slim Line Lamp Standard

We have developed a range of features for our Lowering Trolley Head poles, to make them easy, reliable and above all, safe to use. These features mean that a pole with the relevant options included, can be operated by one man standing on the ground, without the need for steps, or the need to support heavy camera loads, when lowering the camera into the upright maintenance position. This therefore is the safest and easiest to operate Lowering Trolley Head pole available on the market today.

Altron's numerous security design features ensure a good level of protection against vandal attacks.

# → Lowering Trolley Head Poles



AWI502/10LTH/DDA

Height ranges AWI545/LTH & AWI502/LTH 4m - 15m  
Height range AWI502/LTH/I68 Slim-line 4-10m

Altron Lowering Trolley Head Poles enable CCTV equipment to be serviced at ground level, safely, without the need for a man lift or a clear area to tilt the pole over. This is particularly useful in locations where road closures would otherwise be required, pavement locations and pedestrianised areas or where it is not possible to get a man lift and there is no space to tilt the pole over. The AWI545 cabinet based version offers a fully integrated solution, where equipment is mounted in the base of the pole, so no separate street cabinet is required.

## Typically used for the following types of installation

- o Where access to the camera location is restricted
- o Public area urban CCTV
- o Highways
- o Prisons and detention facilities
- o Railway platforms & car parks
- o Car parks
- o Retail Parks
- o Sports stadia

## Security Features

- o Internal cabling
- o Close fitting flush doors
- o Solid secure heavy duty door locks and high security lock
- o Secure venting method
- o Internal padlock facility available to stop unauthorised access to winch mechanism
- o Anchor bolts below ground level

## General Features

- o Stable structures for all camera types
- o Design complies with Highways Agency specification.
- o Trolley Head locks solidly in the raised position by means of a cam lever uplatch, meaning that there is no movement in the Trolley Head when the camera is in operation.
- o AWI545/LTH cabinet based version also available with 500 square cabinet for additional equipment mounting capacity.
- o Flush doors and secure locks as standard, enhance security and appearance.
- o Standard convection venting on AWI545/LTH version eliminates condensation (when the pole base is properly sealed on installation)
- o Unique slim-line version up to 10 metres in height, using a 168 diameter shaft, giving an extremely slim outline silhouette.
- o A wide range of standard Altron Accessories available
- o Constructed in high tensile steel and hot dip galvanised after fabrication for durability
- o Option of painting over the galvanised finish in colours available from BS and RAL colour charts
- o For design, manufacturing and finishing standards, see details on page 107

## Pole Options Explained

Our lowering trolley head pole range is made up of the basic units, part numbers AWI502/LTH and AWI545/LTH. We offer a full range of upgrades as additions to the basic poles, as outlined below. All additional options are explained further in the following pages.

### Basic pole (AWI502/LTH)

Lamp standard version with no back board within the winch compartment. Winch is auto-braking and manually operated and the trolley head neck is fixed. Quick release uplatch included as standard. Trackway is extra.

### Basic pole with cabinet base (AWI545/LTH)

As the AWI502/LTH, but with a cabinet base. There are twin doors as standard, front and back with equipment mounting boards within both compartments. Trackway is extra.

### Addition /DO, Drill Operated dual drum winch

This winch requires the Drill winding unit DW/DO to operate it. This enables the trolley head to be lowered using the DW/DO, rather than the manually operated the winch. Winch has dual drum, so two cables are employed, with the second cable as a failsafe. Trackway is fitted as standard with this option.

### Addition of /TR - Trackway.

The benefit of Trackway, is to keep the trolley head aligned when lowering and raising, in high wind conditions (an extra item on the basic pole models).

### Addition of the /DDA Drop Down Arm.

Our patented Drop Down Arm, enables camera equipment to be brought down to waist height, for maintenance, without having to support the weight of the camera equipment by hand.

### Addition of the /RA, Rotating Arm and /SN-RA Swan Neck Rotating Arm option

This is ideally suited for dome mounting using our swan neck, or for light PTZ applications. This is a cost effective way of getting camera equipment down to ground level for maintenance. We do not recommend this option for heavier PTZ applications, of loads over 10 kgs.

### Addition of /CM, Cable Management

Cable management enables camera cables to be disconnected and marshalled through the pole automatically.

### Cable pulley configurations

A number of pulley configurations are available for the head of the pole, depending on the type of cable being used to feed the camera. Please contact our Sales team who will provide further information and advice.

# Lowering Trolley Head Poles ← Technical Specifications

## AW1502/LTH/168/SN Slimline Lamp Standard

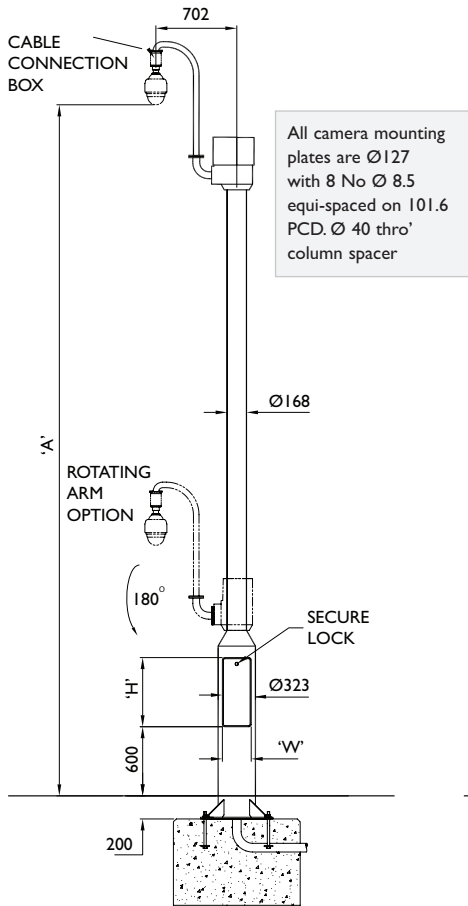

## 1502 LTH Lamp Standard

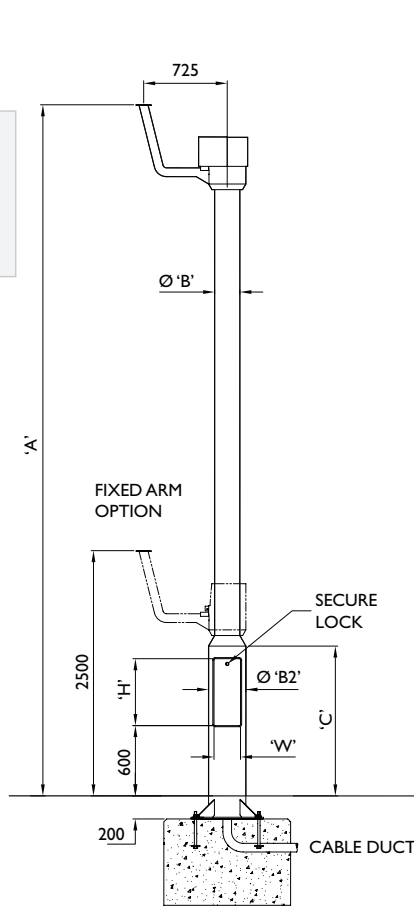

## 1545 LTH Cabinet Based

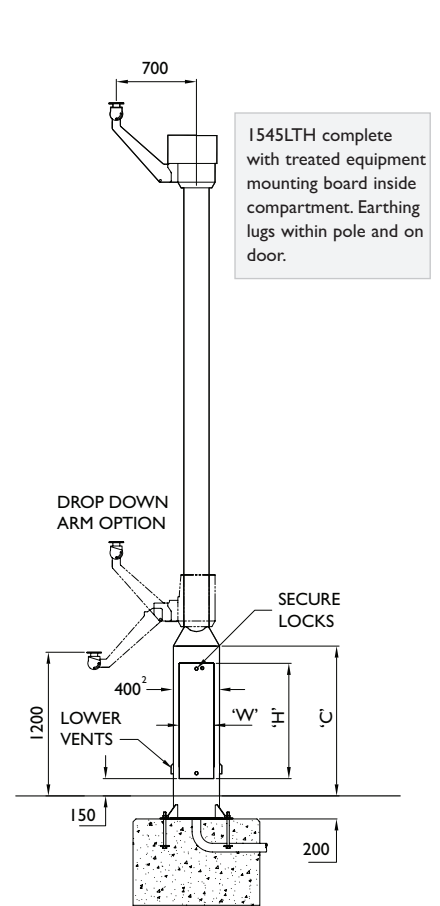

FOR FOUNDATION AND BOLTING DETAILS REFER TO PAGE 58

Model No.	Height in mtrs	Max equip weight at top kgs	Max equip surface area m <sup>2</sup>	Pole ØB	Cabinet height above ground C	Front door size H x W	Rear door size H x W	Product weight kgs
AW1545/4LTH	4	30	0.25	219	1300	970x270	520x270	281
AW1545/5LTH	5	30	0.25	219	1300	970x270	520x270	310
AW1545/6LTH	6	30	0.25	219	1300	970x270	520x270	339
AW1545/7LTH	7	30	0.25	219	1300	970x270	520x270	368
AW1545/8LTH	8	30	0.25	219	1300	970x270	520x270	397
AW1545/9LTH	9	30	0.25	219	1300	970x270	520x270	513
AW1545/10LTH	10	30	0.25	219	1300	970x270	520x270	548
AW1545/10HDLTH	10	30	0.25	273	1300	970x270	520x270	738
AW1545/12LTH	12	30	0.25	273	1300	970x270	520x270	822
AW1545/15LTH	15	30	0.25	273	1300	970x270	520x270	910

Model No.	Height in mtrs	Max equip weight at top kgs	Max equip surface area m <sup>2</sup>	Shaft ØB	Base ØB2	Base height C	Door aperture size H x W	Product weight kgs
AW1502/4LTH	4	30	0.25	219	323	1300	425x177	277
AW1502/5LTH	5	30	0.25	219	323	1300	425x177	306
AW1502/6LTH	6	30	0.25	219	323	1300	425x177	335
AW1502/7LTH	7	30	0.25	219	323	1300	425x177	364
AW1502/8LTH	8	30	0.25	219	323	1300	425x177	393
AW1502/9LTH	9	30	0.25	219	323	1300	425x177	495
AW1502/10LTH	10	30	0.25	219	323	1300	425x177	530
AW1502/10HDLTH	10	30	0.25	273	355	1300	425x177	693
AW1502/12LTH	12	30	0.25	273	355	1300	425x177	777
AW1502/15LTH	15	30	0.25	273	355	1300	425x177	861

### AW1545/LTH & AW1502/LTH Options

Decorative Banding (on Cabinet only)	/B
Altron 4 Point Locking	/A4P
Trackway Upgrade (for manually operated poles)	/TR
Dual drum Winch & Drill Winding Device Upgrade (Includes trackway)	/DO
Drill Winding Device	DW/DO
Drop Down Arm for 15kg camera	/DDA/15
Drop Down Arm for 30kg camera	/DDA/30
Cable Management System (up to 10m)	/CM
Rotating Arm	/RA
Swan Neck Rotating Arm	/SN-RA

### AW1502/LTH only Options

High Security Lock	/HS
--------------------	-----

### AW1545/LTH Cabinet & Door Configurations

Standard cabinet base size is 400<sup>2</sup> Standard door configuration is one full size door on winch access side & one half size door on opposite side.

450sq cabinet	/450
500sq cabinet	/500

### Accessories

#### AW1545/LTH & AW1502/LTH

Manual Winch Winder for Dual Drum Winch	/MWW
Support Bracket for Drill Winding Device	/DSB
Internal Padlock Plate	/IPP

Where payloads are greater than those stated above, please contact Altron  
All dimensions in mm unless stated otherwise

# → Lowering Trolley Head Poles Options & Features

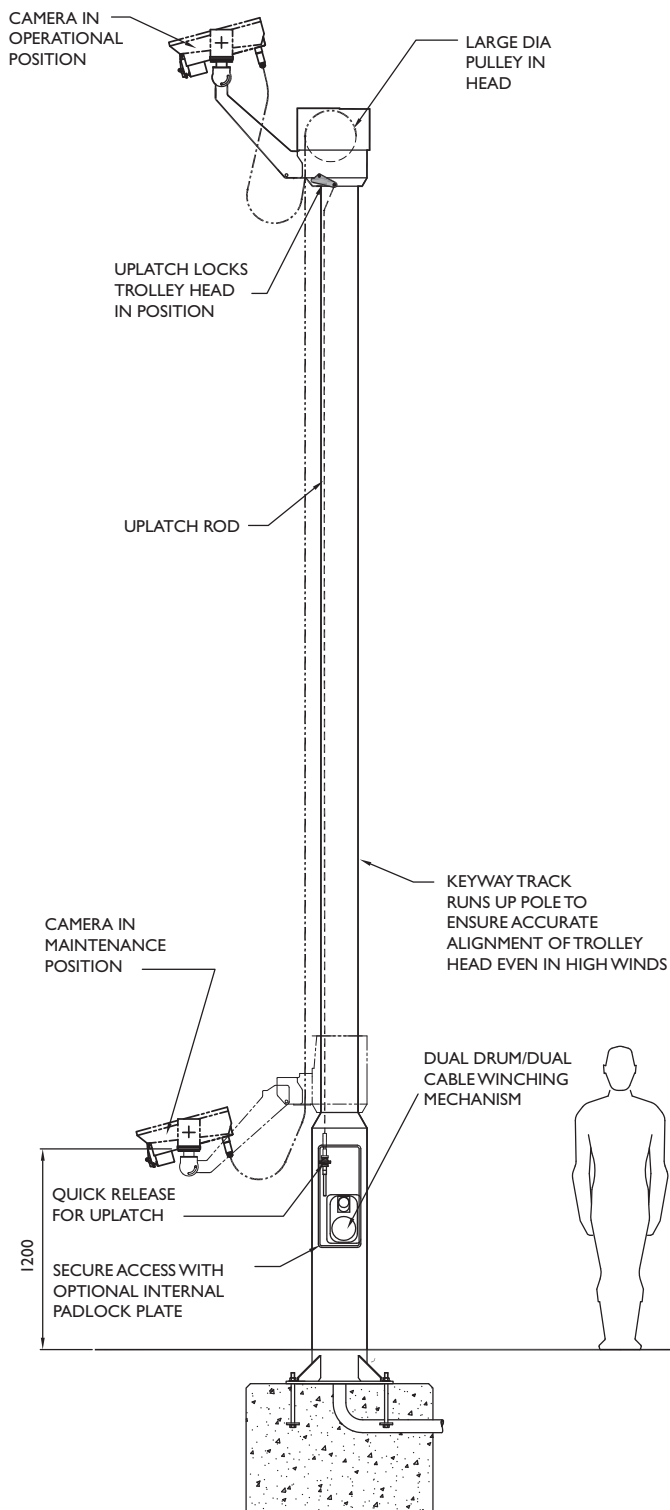

## Uplatch

Uplatch with quick release - Altron's unique cam latch system locks the trolley head into the top canopy so that there is no movement or vibration in the trolley head when raised and means that the winch cables do not hold the trolley head in the raised position. The quick release up-latch mechanism is quick and easy to use.

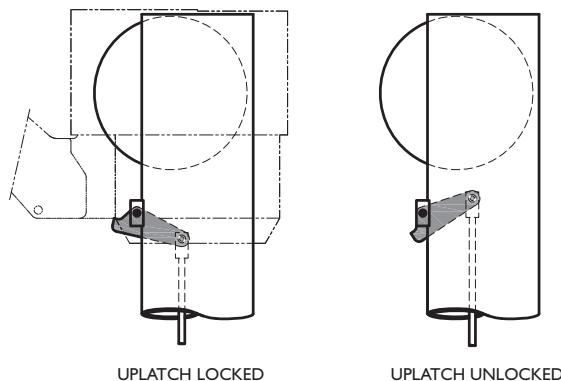

## Cable Management / CM

Altron's unique system means that the camera feeder cables are marshalled inside the pole shaft when the trolley head is being lowered. There is no need for an additional loop of cable or for a lanyard to be held, whilst operating the pole, therefore a one man operation.

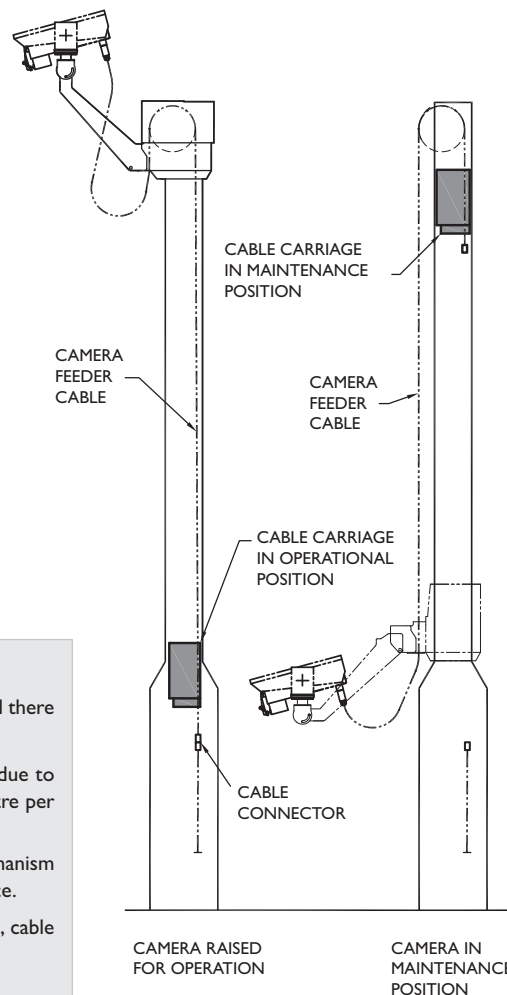

## Safety Features

**Two winch cables** - on DO version, means that there is a failsafe back up cable should there ever be a problem with the main winch cable

**Slow free run speed of dual drum winch** - In the unlikely event of a winch failure, due to the high gearing ratio of the DO winch unit, the trolley head descends at less than 1 metre per second and comes to rest on the pole shoulder, without any damage taking place.

**Failsafe of auto-braking manual winch** - For manual winches, the breaking mechanism closes and locks if the friction brake pad should fail, therefore no run-away can take place.

**Extensive 'full life' testing** - we have gone through rigorous testing of the winch, cable and trolley head components to replicate more than 10 years of operation. All parts are manufactured to be either maintenance free, or give maximum life to first maintenance.

# Lowering Trolley Head Poles ← Options & Features

## Drop Down Arm / DDA (Patent No. 2476970)

The Drop Down Arm enables camera servicing in the upright position at ground level without the need for steps. The arm takes the weight of the camera equipment so this is an easy, one man operation that is safe to carry out. Camera loads of up to 30kgs can be safely lowered.

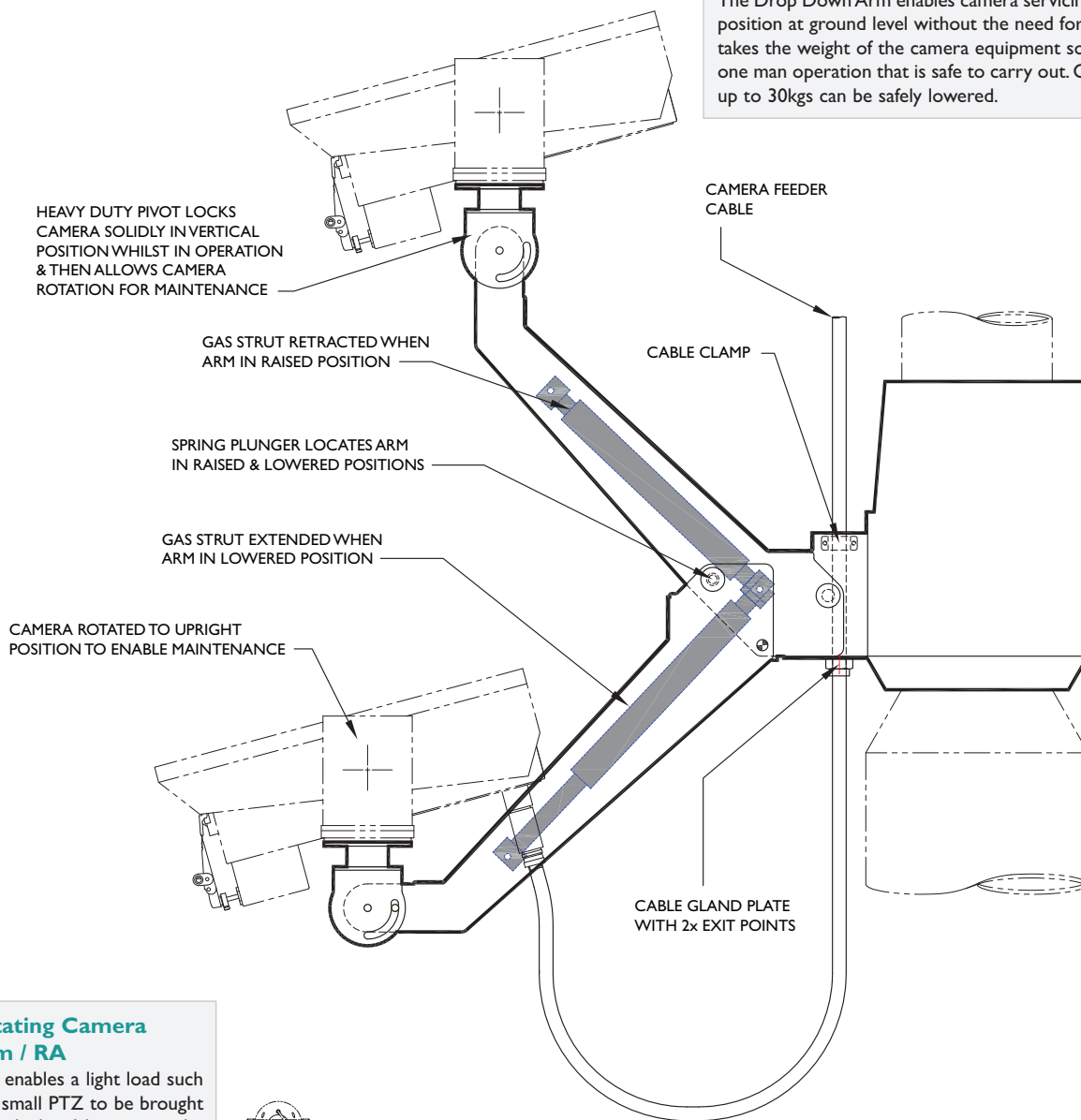

## Rotating Camera Arm / RA

This enables a light load such as a small PTZ to be brought down by hand, by rotating the camera arm downwards, supporting the load by hand. The arm can be set up on site so that it rotates either to the left or to the right. Camera cables can be fed internally through the arm or glanded to the outside.

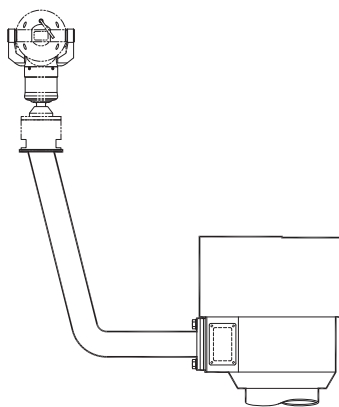
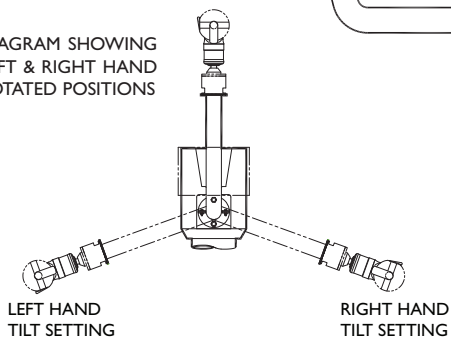

DIAGRAM SHOWING LEFT & RIGHT HAND ROTATED POSITIONS



Drop down arm in raised position



Drop down arm in lowered position

# → Lowering Trolley Head Poles Options & Features

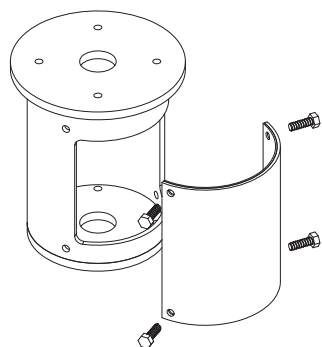

## Cable Connection Box /CCB

This is a water proof box with a removable front panel with sufficient space to allow cable connectors to fit inside. It can be provided with glanded entry and exit.

## Swan Neck Rotating Arm /SN-RA

The swan neck lifts the dome above the top of the pole for better coverage and the rotating arm allows the dome to be brought down for maintenance. The arm can be set up on site so that it rotates either to the left or to the right. A connection box can be fitted above the dome so that cable connections can be made close to the dome.

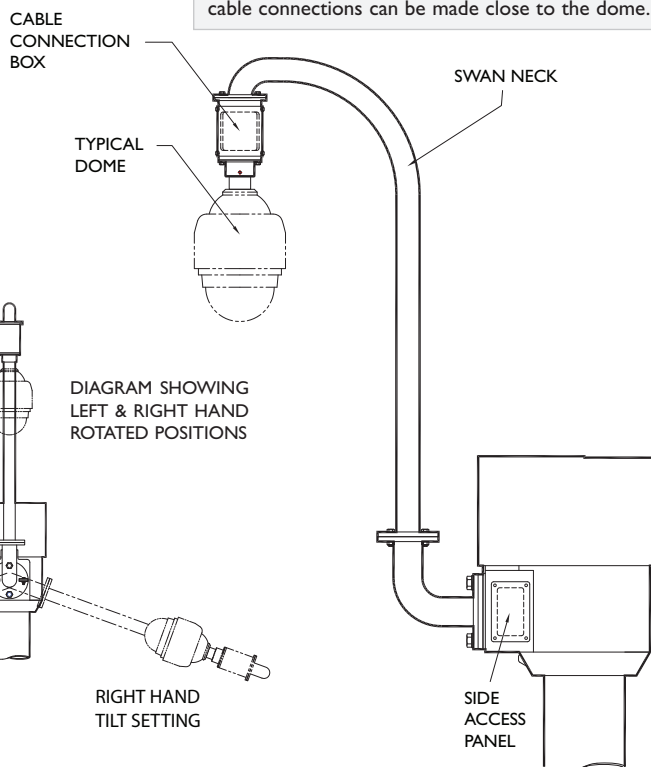

SN-RA Swan Neck Rotating Arm

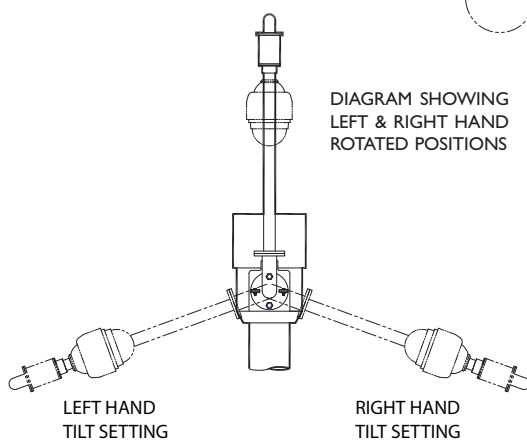

LEFT HAND  
TILT SETTING

RIGHT HAND  
TILT SETTING

SIDE  
ACCESS  
PANEL

## Dual Drum Winch / DO Drill Winding Device DW/DO

Dual Drum Winch and Drill Winding Device - The dual drum winch gives complete safety with a second 'safety' winch rope. The drill winding device uses the latest battery technology with a speed limiter and torque lock upgrade, specifically for this application to ensure safe, reliable operation. The Drill winding device is light and transferable, so one device can service many poles. This upgrade meets the requirements of PLG07.



DO - Dual drum winch



DW/DO Drill winder hand held



DSB - Drill Support Bracket, with  
Drill winder located in bracket

## Drill Support Bracket / DSB

Drill Winding Device Support Bracket - this can be incorporated for easy one hand operation and takes the weight of the drill winding device, so operating the pole could not be easier.

## Trackway / TR

Trackway Upgrade - Trackway keeps the trolley head running true, when lowering and raising even in very windy conditions. This is standard on /DO pole versions.



TR Trackway

## Internal Padlock Plate / IPP

This is a close fitting internal plate that sits behind the main door, and only comes into view once the door is removed. It will withstand lever attacks and is a second line of defence to make our lowering trolley head poles extremely secure against vandal attacks.



IPP Internal Padlock Plate